

# JUXTA F Series General Specification

Model FX3□-PH (Variable software type)  
FX4□-PH (Fixed software type)  
Peak Holder

JUXTA

## 1. GENERAL

This is a variable or fixed software type computing unit which accepts two mV signal input points or one mV signal and one contact signal input point from various converters, and outputs an isolated DC voltage or current signal corresponding to the peak value when hold command input signal is more than 75% (at hold command input OFF).

## 2. SPECIFICATIONS

Model No.	FX3A-PH, FX3V-PH	FX4A-PH, FX4V-PH
Input signal	mV signal: 2 points	mV signal: 1 point Contact point input: 1 point
Measuring range	-2 to 10 mV (There is accuracy limitation for spans of more than 3 mV and less than 10 mV.) -10 to 50 mV (For span of more than 10 mV) -50 to 250 mV (for span of more than 50 mV) -100 to 1250 mV (For span of more than 250 mV) (*1)	
Input resistance	1 MΩ (At power failure: More than 3 KΩ)	
Output signal	4 to 20 mA, 2 to 10 mA, 1 to 5 mA, 0 to 20 mA, 0 to 16 mA, 0 to 10 mA or 0 to 1 mA DC 0 to 10 mV, 0 to 100 mV, 0 to 1 V, 0 to 10 V, 0 to 5 V, 1 to 5 V or -10 to +10 V DC	
Basic accuracy	±0.2% of measuring span	
Signal insulation	Between input signal and output signal/power supply circuits, and between output signal and power supply circuits	
Insulation resistance	Between input signal and output signal/power supply circuits Between output signal and power supply circuits: 100 MΩ/500 V DC	
Dielectric strength	Between input signal and output signal/power supply circuits: 1500 V AC/min Between output signal and power supply circuits: 500 V AC/min	
Power supply voltage	24 V DC ±10%	
Ambient temperature/humidity	0 to 50°C (32 to 122°F) and 5 to 93% relative humidity (No condensation)	
Effect of ambient temperature	±0.2% of span for 10°C (50°F) change	
Effect of power supply voltage	±0.2% of span for 24 V DC variation	
Power consumption	24 V DC, 56 mA (Voltage output) and 24 V DC, 78 mA (Current output)	
Dimensions	72 (2.83") H × 24 (0.94") W × 127 (5.00") D mm (inch)	
Weight	Approx. 130 g	
Accessories	Tag number label : 1 sheet Mounting blocks: 2 pcs.	

(\*1) Specify measuring range from □ to □mV.

Range accuracy for span of less than 10 mV:  $0.2 \times 10 / (\text{mV input span}) \%$

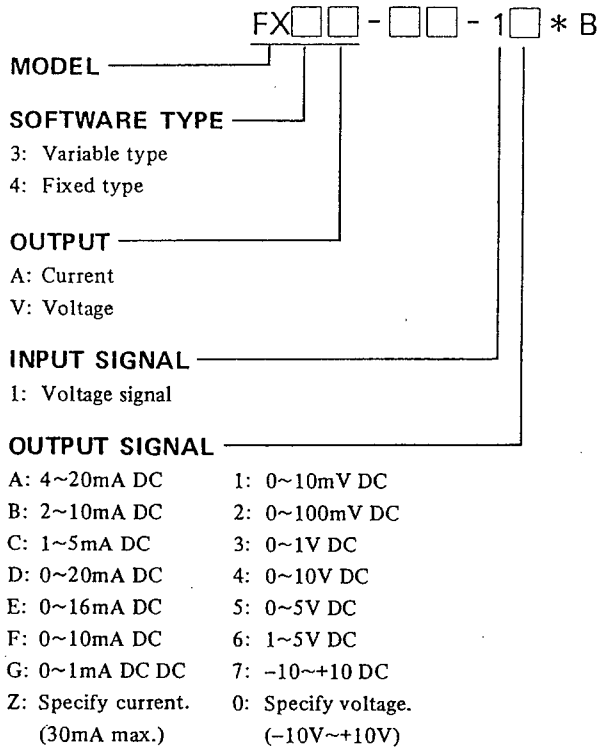

Ordering Information

Input Measuring Range		
Range name	Allowable min. span	Allowable Measuring Range
HH	250 mV	-100 ~ 1250 mV
H	50 mV	-50 ~ 250 mV
L	10 mV	-10 ~ 50 mV
LL	3 mV	-2 ~ 10 mV
However, accuracy of less than 10 mV span is $0.2\% \times \frac{10 \text{ mV}}{\text{Input span (mV)}} (\%)$		
Recommended Input Range		
Voltage signal	0 ~ 10 mV DC 0 ~ 100 mV DC 0 ~ 1V DC	

**OUTPUT RESISTANCE AND LOAD RESISTANCE**

Output Signal	Load Resistance	Output Impedance
4 to 20mA DC	0 to 750Ω	5MΩ or more
2 to 10mA DC	0 to 1500Ω	
1 to 5mA DC	0 to 3000Ω	
0 to 20mA DC	0 to 750Ω	
0 to 16mA DC	0 to 900Ω	
0 to 10mA DC	0 to 1500Ω	
0 to 1mA DC	0 to 15kΩ	

Output Signal	Load Resistance	Output Impedance
0 to 10mV DC	100kΩ or more	100Ω or less
0 to 100mV DC		
0 to 1V DC	2kΩ or more	1Ω or less
0 to 5V DC		
1 to 5V DC		
0 to 10V DC	10kΩ or more	
-10 to +10V DC		

Subject to change without notice for grade up quality and performance